



WORKSHEET ES-4

Giochi di Silabe

Obiettivi: consapevolezza fonologica (sillabica) e miglioramento di memoria, attenzione e discriminazione visive per aiutare l’acquisizione delle abilità di lettura .

Attività 1 Trova la parola nascosta

Attività individuale/età di riferimento : 7-11

Tempo: 20 minuti

Regole: 1) L’insegnante assegna un documento interattivo nel computer con diverse diapositive
2) Lo student deve completare gli spazi bianchi con sillabe per trovare la parola nascosta che è una delle figure sotto .

Materiali richiesti: un PC per ogni studente .

Un esempio :

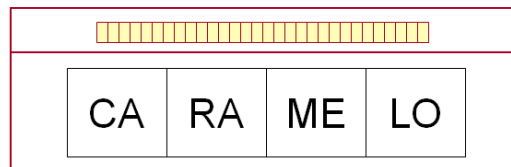
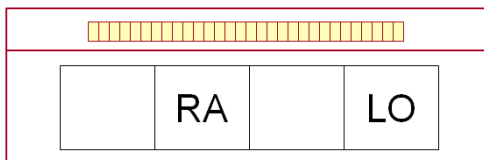

Attività 2 Identificare e riordinare le sillabe

Attività individuale/età di riferimento : 7-11

Tempo: 20 minuti

Regole: 1) L’insegnante assegna un document interattivo al computer con diverse diapositive

2) (viene dopo la prima attività)Lo studnete deve identificare se la sillaba data è parte della parola mostrata in figura .

3)Metti la sillaba dove si adatta.

Materiali richiesti : un Pc per ogni studente.

Un esempio :

The image shows three examples of a reading activity. Each example consists of a candy icon, a word grid, and a syllable box. The word grid is a 2x4 grid with a red bar above it. The syllable box is a 1x2 grid with an arrow pointing right.

Example 1: The word grid contains four empty boxes. The syllable box contains 'LO' and an arrow pointing right.

Example 2: The word grid contains three empty boxes followed by 'LO'. The syllable box contains 'GA' and an arrow pointing right.

Example 3: The word grid contains three empty boxes followed by 'LO'. The syllable box contains 'DA' and an arrow pointing right.

Attività 3 **Ordinare le sillabe e formare una parola**

Attività individuale/ Età di riferimento : 7-11

Tempo: 20 minuti

Regole : 1) L’insegnante assegna un documento interattivo al computer con diverse diapositive .

2) Lo student deve ordinare le sillabe per formare una parola .

Materiali richiesti : un PC per ogni studente

Un esempio:

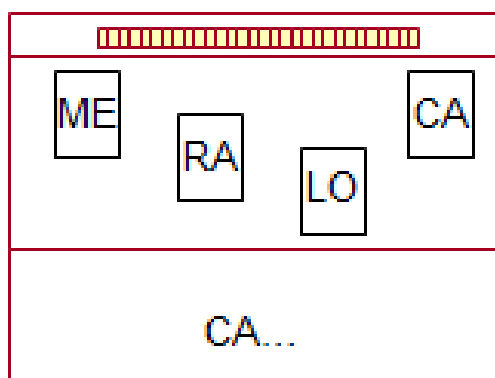
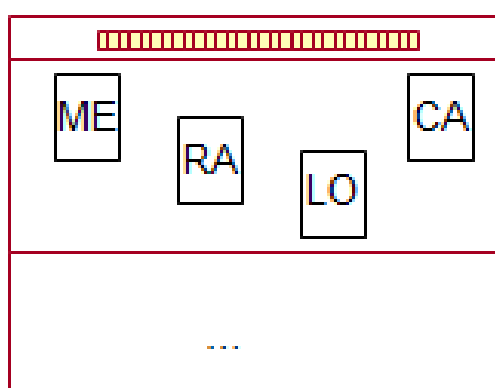

Attività 4 **Dividere in sillabe**

Attività individuale/Età di riferimento : 7-11

Tempo: 20 minuti



Regole: 1) L’insegnante assegna un documento interattivo al computer con diverse diapositive .

2) Lo student deve divider le parole in sillabe.

Materiali richiesti : un computer per ogni studente

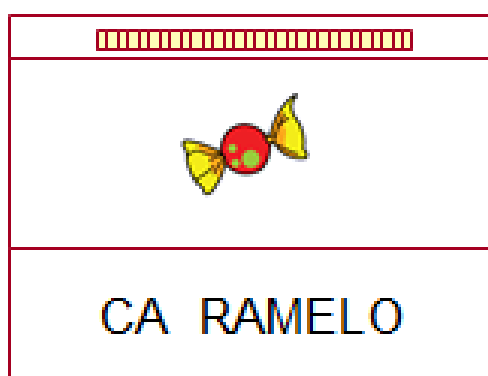
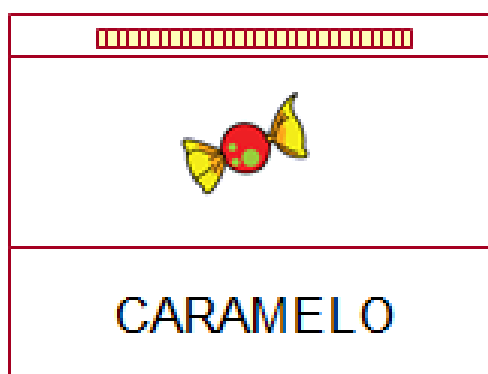
Un esempio:





CA RA MELO





CA RA ME LO

