



## FICHA DE TRABALHO 3

### Sensibilização fonológica direta

**Objetivos:** Melhorar a memória, a atenção e a discriminação visual na aprendizagem da leitura.

#### Atividade 1

**Título:** Encontre a palavra oculta /Atividade Individual/ **Grupo etário:** 7-11 anos **Tempo:** 20 minutos

**Regras:** 1) O professor mostra, no computador, um documento interativo com diferentes imagens.  
2) O aluno tem de completar os espaços em branco com sílabas, para encontrar a palavra oculta, a qual corresponde a uma das imagens.

**Materiais necessários:** Um computador para cada aluno.

#### Exemplo:

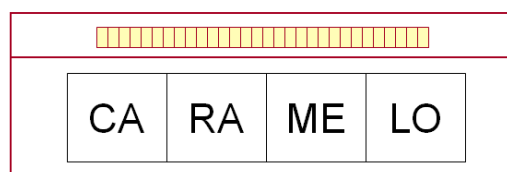
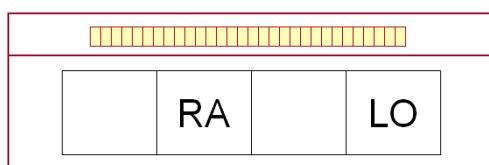

## **Atividade 2**

**Título: Identificar e ordenar sílabas**

**Grupo Etário: 7-11 anos**

**Tempo: 20 minutos**

**Regras:** 1) O professor mostra, no computador, um documento interativo com diferentes imagens.  
2) (Segue-se à atividade anterior.) O aluno tem de identificar se uma determinada sílaba faz parte da palavra visualizada na imagem.  
3) O aluno coloca a sílaba no lugar correto.

**Materiais necessários:** Um computador para cada aluno.

**Exemplo:**

Activity 1: A red-bordered box containing a candy icon, a progress bar, four empty boxes, and a box with 'LO' and an arrow.

Activity 2: A red-bordered box containing a candy icon, a progress bar, three empty boxes, and a box with 'LO' and an arrow.

Activity 3: A red-bordered box containing a candy icon, a progress bar, two empty boxes, and a box with 'LO' and an arrow.



**Atividade 3**

**Título:** Ordenar as sílabas de uma palavra  
**minutos**

**Grupo Etário:** 7-11 anos

**Tempo:** 20

- Regras:** 1) O professor mostra, no computador, um documento interativo com diferentes imagens.  
2) O aluno tem que ordenar as sílabas para formar uma palavra.

**Materiais necessários:** Um computador para cada aluno.

**Exemplo:**

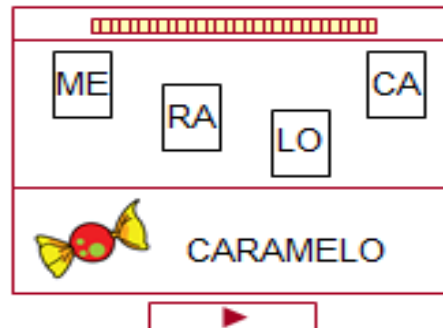
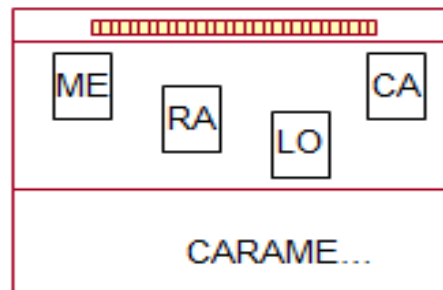
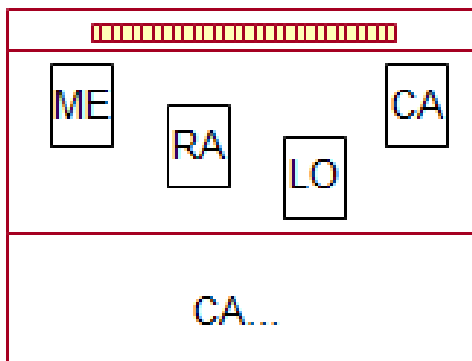
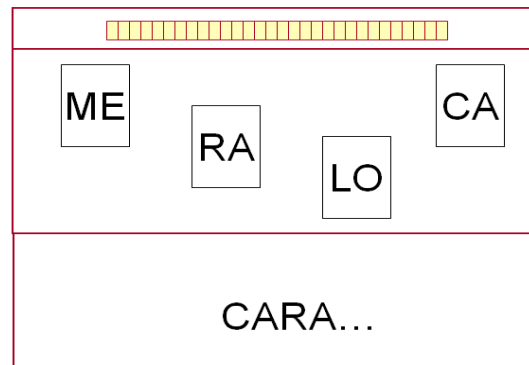
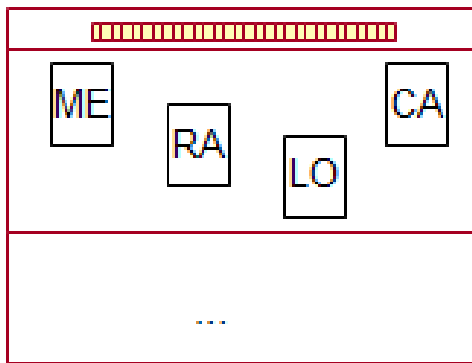

**Atividade 4**

**Título:** Separar em sílabas

**Grupo Etário:** 7-11 anos

**Tempo:** 20 minutos

**Regras:** 1) O professor mostra, no computador, um documento interativo com diferentes imagens.  
2) O aluno separa as palavras em sílabas.

**Materiais necessários:** Um computador para cada aluno.

**Exemplo:**

